

MPJ-M series

Double Column Type Machining Center

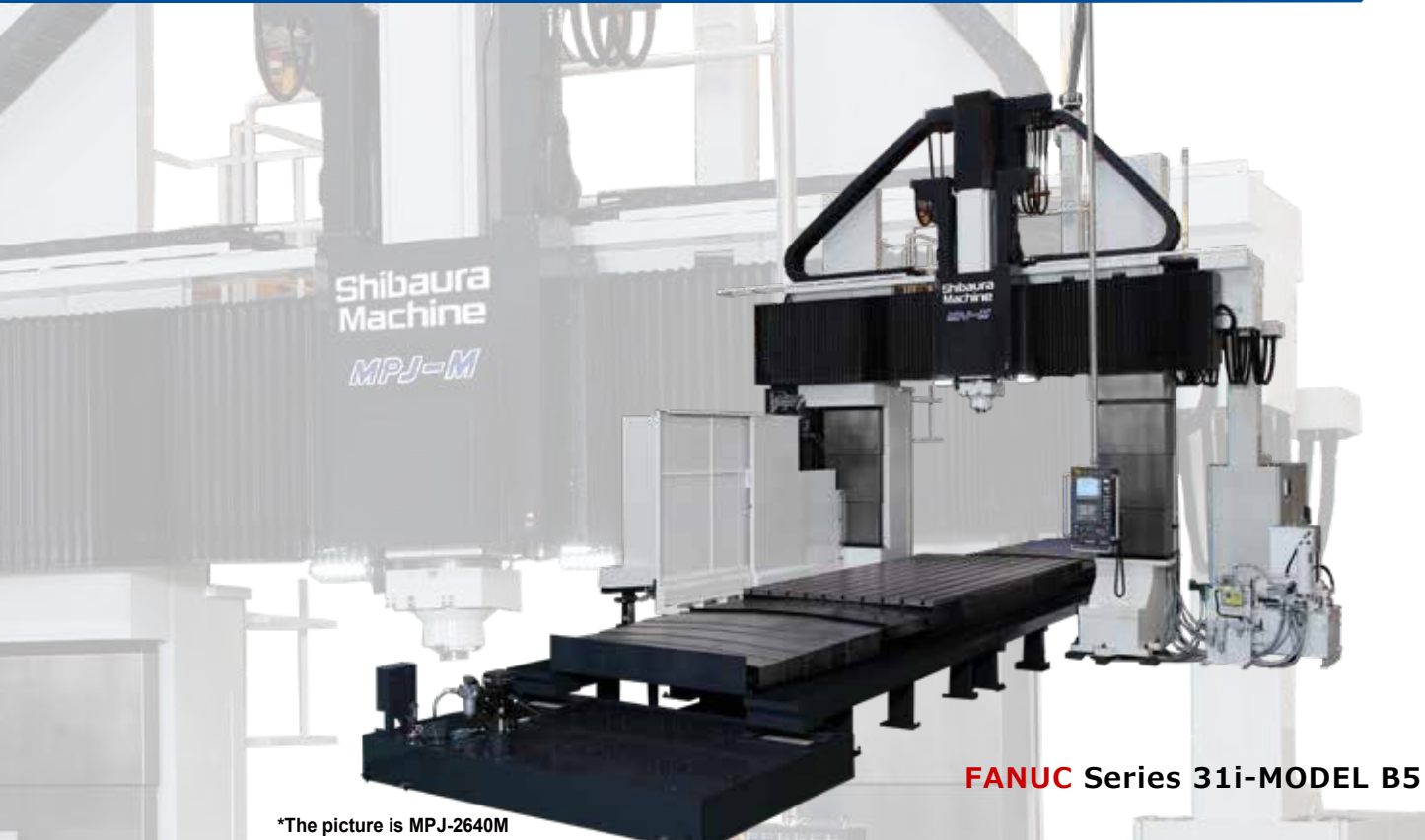

FANUC Series 31i-MODEL B5

*The picture is MPJ-2640M

Machine Specifications			MPJ-2640M
Travel	X-axis travel (Movement of table)	mm [in]	4 500 [177]
	Y-axis travel (Cross movement of spindle head)	mm [in]	3 000 [118]
	Z-axis travel (Vertical movement of Ram)	mm [in]	800 [31.5]
	W-axis travel (Movement of Cross rail)	mm [in]	1 000 [39.4]
Table	Table working surface	mm [in]	2 000x4 000 [78.7x157.5]
	Table loading capacity	kg [lbs]	25 000 [55 115]
Spindle	Spindle maximum torque	Nm [lbs.ft]	653 [481.7]
	Spindle speed range	min-1	40 to 10 000
Feedrate	Rapid traverse rate	X,Y m/min [ft/min]	20 [65.6]
		Z m/min [ft/min]	10 [32.8]
		W m/min [ft/min]	1 [3.3]
	Feedrate	mm/min [ipm]	1 to 15 000 [0.04 to 590.6]
Spindle motor	30 min.rating / cont.rating	kW [HP]	AC45/37 [AC60/50]
Accuracy	Positioning	X,Y,Z mm [in]	±0.007 [±0.0003]
	Repeatability	X,Y,Z mm [in]	±0.003 [±0.00012]
Machine size	Height x Width x Depth	mm	6200 x 11100 x 6740
		in	244.1 x 437.0 x 265.4

*We have other size, please contact from below Email.

Shibaura Machine

755 Greenleaf Avenue | Elk Grove Village, IL 60007 | mt-sales@shibaura-machine.com

Attachments Accessories



Angle Head



30 deg. Angle Head



1 deg index Head



Auto Attachment Changer

Machine General Views

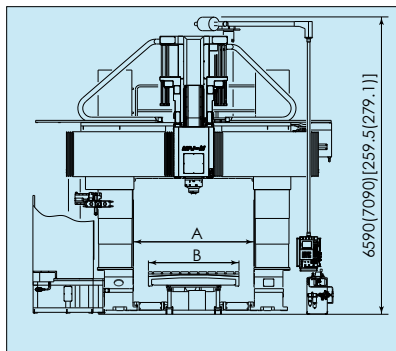

*) dimension is when choose high type.

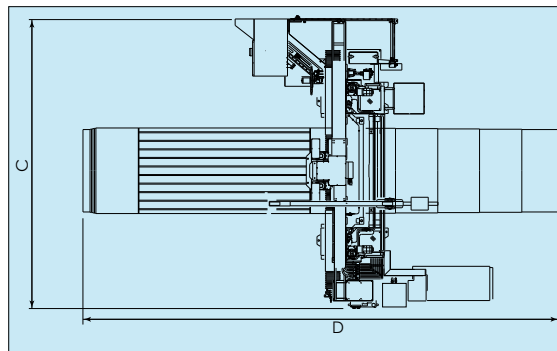

	MPJ-2640M	MPJ-2650M	MPJ-2660M	MPJ-3140M	MPJ-3150M	MPJ-3160M
A		2 600 [102.4]			3 100 [122.1]	
B		2 000 [78.7]			2 500 [98.4]	
C		6 590 [259.45]			7 090 [279.1]	
D	11 100 [437]	13 100 [515.8]	15 100 [594.5]	11 100 [437]	13 100 [515.8]	15 100 [594.5]

Machine Accessories

FANUC 31i-Model B5
 600mm[24in] Tool for ATC magazine
 BIG PLUS spindle
 Auto power shut down
 CTS
 HEIDENHAIN feed back scale X,Y,Z
 Z axis Thermal compensation

Number of Auto Tool Change : 36,60,90,120,180
 CAT 50
 Auto Attachment Changer
 Auto Attachment Index Every 5deg or 1deg
 Auto measurement function
 Ball screw cooling unit

Shibaura Machine

755 Greenleaf Avenue | Elk Grove Village, IL 60007 | mt-sales@shibaura-machine.com
<https://www.shibaura-machine.com/>